



Installation Instructions



PRODUCT: JK RockSport Steering Stabilizer Kit

REV: A | 07-14-2016 | II-7133

**READ INSTRUCTIONS IN FULL BEFORE INSTALLATION.
QUESTIONS? CALL 916-631-8071 M-F 7:00 AM – 5:00 PM PST**

The MetalCloak experience includes the ease of installation of our products. We design for most contingencies, but installation may be different based on different Jeep condition, configuration and/or year.

We are continually trying to improve our products and instructions – please help us by providing feedback and pictures if you find any part of the instructions that do not match your particular Jeep or are not easily understandable.

If you have any difficulties at all, please give us a call. Thank you and enjoy your MetalCloak Products!

IMPORTANT NOTE: We use Stainless Steel Hardware where possible. Therefore, a tube of Silver Anti-seize is provided and should be used on all bolts—only a small amount is needed.

WARRANTY INFORMATION: This article is sold without warranty expressed or implied. No warranty or representation is made as to this products ability to protect the user from injury or death. The user assumes that risk. The effectiveness, warranty and longevity of this equipment are directly related to the manner in which it is INSTALLED, USED and/or MAINTAINED. THE USER ASSUMES ALL RISK. By purchasing this product and opening the packaging, purchasers expressly acknowledge, understand and agree that they take, select and purchase these MetalCloak products from Armored Works, LLC, its affiliates and distributors and agents as is and with all faults. The entire risk as to the quality and performance of these MetalCloak products is with the purchaser. Working on your vehicle can be a dangerous activity. If you are unsure of what you are doing, please leave mechanical or safety critical work to a skilled mechanic. We take no responsibility for the incorrect use and/or installation of MetalCloak products.

Section 1: Tools & Notes on Installation



Tools Required: This list is the recommended tools for ease of installation. Other versions of the same tool can be used. For example, Allen Wrenches instead of Allen Drive Sockets.



Ratchet

10MM Socket 14MM Socket
15MM Socket 18MM Socket
19MM Socket 21MM Socket



18MM Wrench

Tape Measure



HOW TO USE THIS GUIDE: The installation guide contains ALL steps for installation. Please read and follow the instructions in order of each page top to bottom, and left to right.

Jeep Model: Instructions may apply to multiple Jeep models, but are labeled separately where appropriate (i.e. TJ vs. LJ).

Options: Because of the number of component options we offer, these instructions may contain steps that will not match your particular configuration. You can skip these steps.

Images: Pictures are provided and parts are labeled throughout the instructions. Each text box contains guidance based on the pictures next to it. The text will refer to alphabetical labels (A, B, etc.) found in the images.

Installation Notes: Terms may be used in the body of the instructions that you may not be familiar with, if you have any questions feel free to contact us at the number below, or email techhelp@metalcloak.com

QUESTIONS: Any questions or comments about the instructions? Call us at 916-631-8071 M-F 7:00 AM – 5:00 PM PST.

Section 2: Product Components

DC-0001 REV A

SHEET 1 OF 1

ITEM	PART NUMBER/DESCRIPTION	QTY.
1	7080 STEERING STABILIZER-AXLE MOUNT, JK	1
2	SS-1223 STEERING STABILIZER SHOCK, ROCKSPORT	1
3	FA-0038 WASHER, .53ID X 1.06OD X .074TH ZNC PLT	2

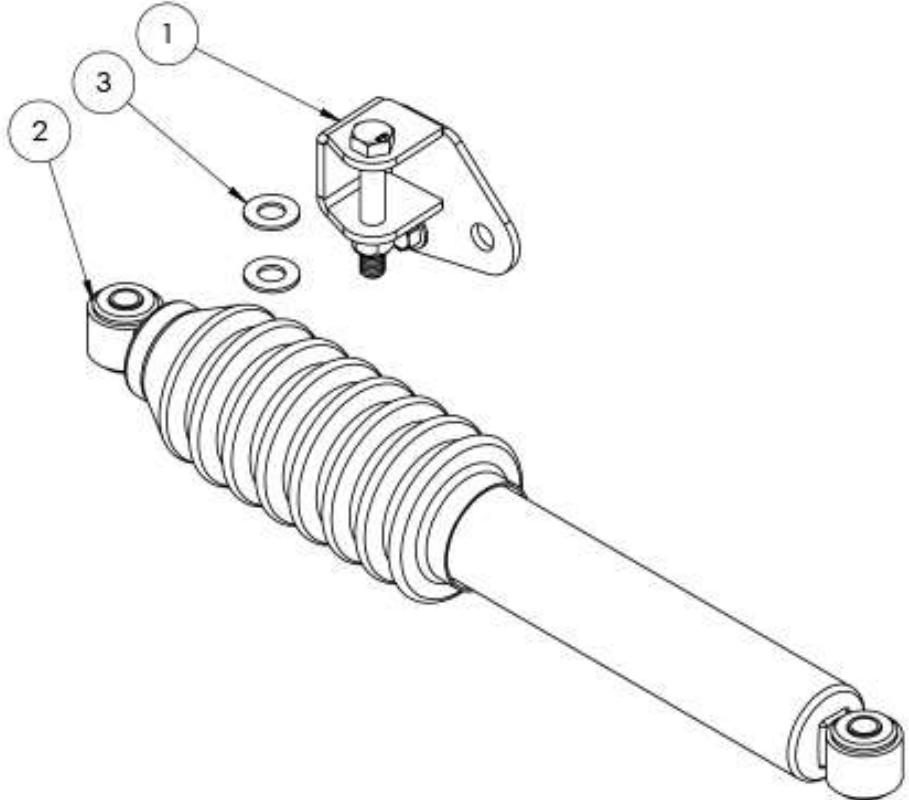

THE INFORMATION CONTAINED ON THIS DRAWING IS THE EXCLUSIVE PROPERTY OF ARMORED WORKS, LLC. UNAUTHORIZED REPRODUCTION IS PROHIBITED.
DO NOT SCALE DRAWING

Metal Cloak

A DIVISION OF ARMORED WORKS, LLC

PART NUMBER 7133 STEERING STABILIZER KIT, ROCKSPORT, JK

DESCRIPTION

Section 3: Installation Instructions



Note: *MetalCloak's RockSport Steering Stabilizer will work with the factory steering stabilizer tie rod mount. The MetalCloak RockSport Steering Stabilizer is shown in conjunction with the MetalCloak's Steering Stabilizer Tie Rod Mount (Product Code: 7086).*

Section 3: Installation Instructions

Step 1: Disconnect Stock Components

- A. Using a 18mm socket disconnect the tie rod end of the factory stabilizer.
- B. Using a 18mm socket disconnect the axle end of the factory stabilizer.
- C. Loosen the tie rod bracket using a 15mm socket (*factory tie rod bracket*) or a 10mm socket (*MetalCloak tie rod bracket*).
- D. Using a 21mm socket disconnect the axle side of the track bar. **Keep all Hardware**

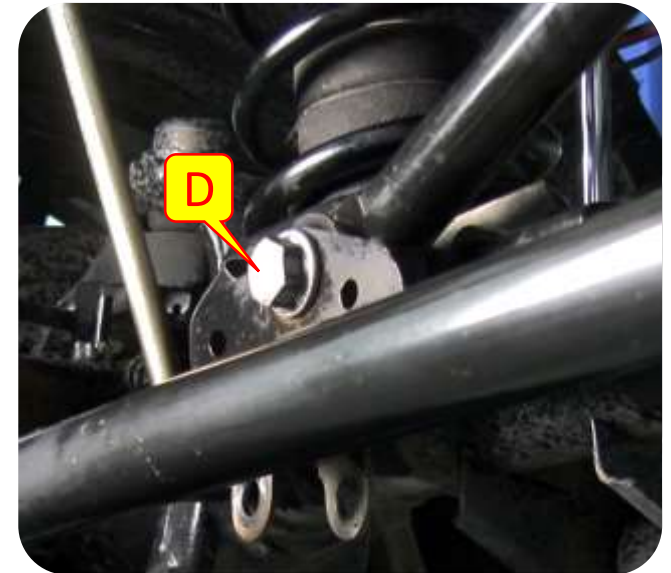
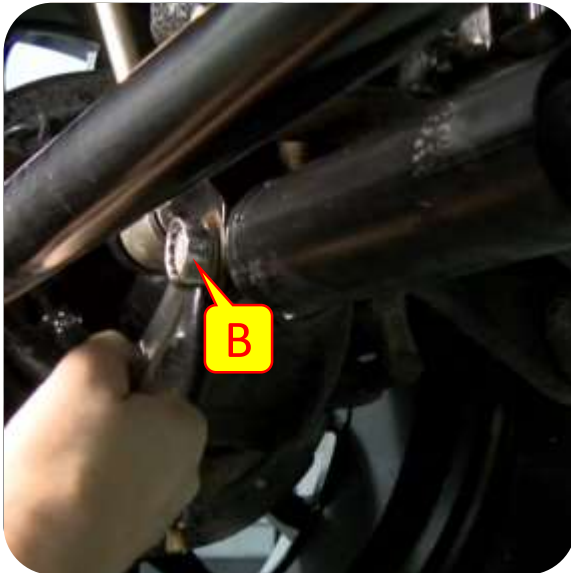
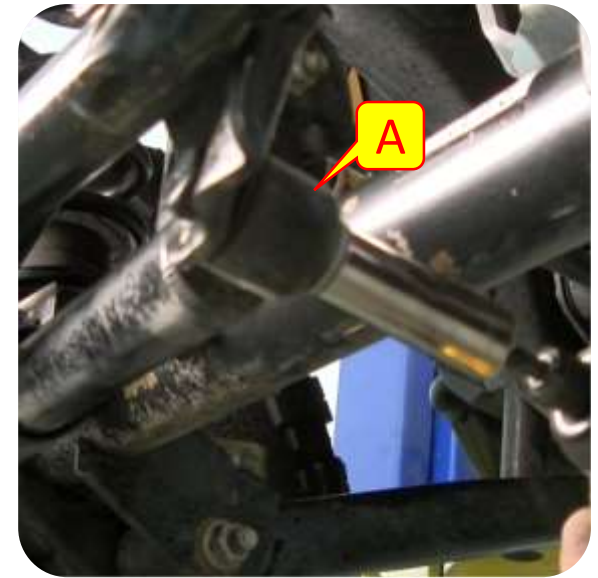

Note: Do not remove the tie rod bracket unless it is being replaced.

Section 3: Installation Instructions

Step 2: Install Steering Stabilizer Axle Mount

- E. Install the axle bracket using the provided hardware hand tight.
- F. Using the stock hardware reinstall the axle side of the track bar.
- G. Tighten the axle side bracket using a 14mm socket.

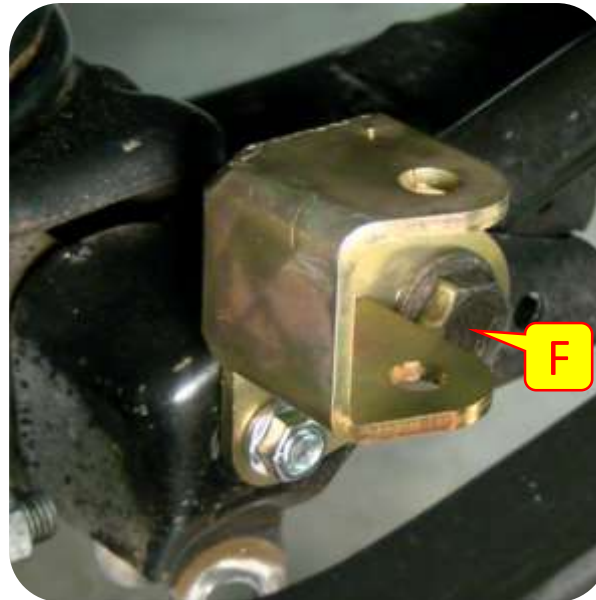

Section 3: Installation Instructions

Step 3: Install the RockSport Steering Stabilizer

- H. Measure the RockSport steering stabilizer to approximately 16" eye to eye.
- I. Install the axle side of the RockSport steering stabilizer using the provided hardware hand tight.
- J. Move the tie rod bracket to the new location and tighten the tie rod end of the stabilizer with an 18mm socket (*factory tie rod bracket*) or 19mm socket (*MetalCloak Tie Rod Bracket*).
- K. Tighten the axle side of the stabilizer with a 19mm socket and wrench.
- L. Tighten the tie rod mount to the tie rod using a 15mm socket (*factory tie rod bracket*) or a 10mm socket (*MetalCloak tie rod bracket*).

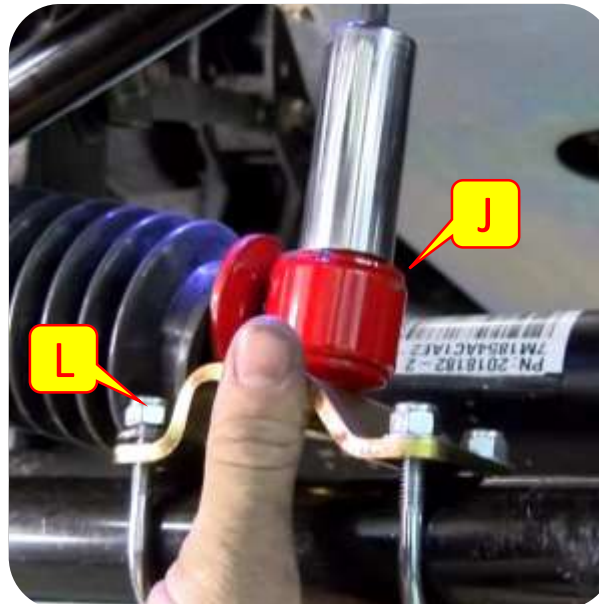

Section 3: Installation Instructions



Note: *MetalCloak's recommends after installation that you check your steering by turning the wheel "from lock to lock" by turning the wheel all the way to the right and then all the way to the left; make sure there is not any interference that may limit the turning radius of the Jeep.*