



Installation Instructions



PRODUCT: JK Front Upper Control Arms

REV: E | 01-19-2023 | II-7002

READ INSTRUCTIONS IN FULL BEFORE INSTALLATION.

QUESTIONS? CALL 916-631-8071 M-F 7:00 AM – 5:00 PM PST

The MetalCloak experience includes the ease of installation of our products. We design for most contingencies, but installation may be different based on different Jeep condition, configuration and/or year.

We are continually trying to improve our products and instructions – please help us by providing feedback and pictures if you find any part of the instructions that do not match your particular Jeep or are not easily understandable.

If you have any difficulties at all, please give us a call. Thank you and enjoy your MetalCloak Products!

IMPORTANT NOTE: We use Stainless Steel Hardware where possible. Therefore, a tube of Silver Anti-seize is provided and should be used on all bolts—only a small amount is needed.

WARRANTY INFORMATION: This article is sold without warranty expressed or implied. No warranty or representation is made as to this products ability to protect the user from injury or death. The user assumes that risk. The effectiveness, warranty and longevity of this equipment are directly related to the manner in which it is INSTALLED, USED and/or MAINTAINED. THE USER ASSUMES ALL RISK. By purchasing this product and opening the packaging, purchasers expressly acknowledge, understand and agree that they take, select and purchase these MetalCloak products from Armored Works, LLC, its affiliates and distributors and agents as is and with all faults. The entire risk as to the quality and performance of these MetalCloak products is with the purchaser. Working on your vehicle can be a dangerous activity. If you are unsure of what you are doing, please leave mechanical or safety critical work to a skilled mechanic. We take no responsibility for the incorrect use and/or installation of MetalCloak products.

Section 1: Tools & Notes on Installation



Tools Required: This list is the recommended tools for ease of installation. Other versions of the same tool can be used. For example, Allen Wrenches instead of Allen Drive Sockets.



Socket & Ratchet Wrench

18mm Socket/Wrench
19mm Socket/Wrench



Cut wheel

Safety Glasses



HOW TO USE THIS GUIDE: The installation guide contains ALL steps for installation. Please read and follow the instructions in order of each page top to bottom, and left to right.

Jeep Model: Instructions may apply to multiple Jeep models, but are labeled separately where appropriate (i.e. TJ vs. LJ).

Options: Because of the number of component options we offer, these instructions may contain steps that will not match your particular configuration. You can skip these steps.

Images: Pictures are provided and parts are labeled throughout the instructions. Each text box contains guidance based on the pictures next to it. The text will refer to alphabetical labels (A, B, etc.) found in the images.

Installation Notes: Terms may be used in the body of the instructions that you may not be familiar with, if you have any questions feel free to contact us at the number below, or email techhelp@metalcloak.com

QUESTIONS: Any questions or comments about the instructions? Call us at 916-631-8071 M-F 7:00 AM – 5:00 PM PST.

Section 3: Product Components



DC-0001 REV A

SHEET 1 OF 1

ITEM	PART NUMBER/DESCRIPTION	QTY.	BIN
1	FS-08125 HHCS FLANGE, 0.5-13 X 3.25L STL G8 ZINC	1	-
2	FS-08127 NYLOCK FLANGE NUT, 0.5-13 X 0.56H STL GF ZINC	1	F6
3	FS-16121 JAM NUT, 1.0-14 X 0.55H STL G5 ZINC	2	-
4	SS-1023 RETAINING WASHER, 1.87 DIA	4	
5	SS-1032 DUROFLEX BUSHING, 2.25D X 2.0L X .50ID	2	
6	SS-1039 FORGED 2.25IN DUROFLEX SPUD, STRAIGHT	2	
7	SS-1051 INT RET RING, 1.87 BORE YEL ZINC	2	
8	WM-5014 CLEVIS JOINT, UPPER CONTROL ARM JK	2	

NOTES

- 1) SET LENGTH = 18-3/4"
- 2) STOCK LENGTH = 18-3/4"

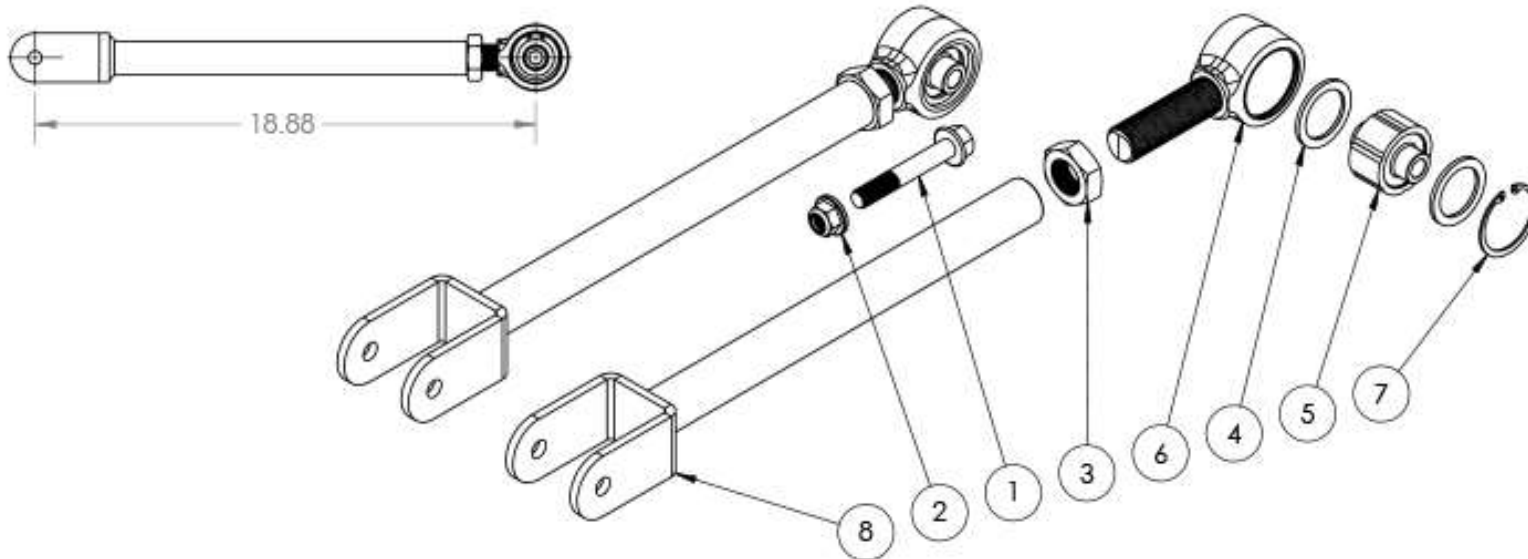

THE INFORMATION CONTAINED ON THIS DRAWING IS THE EXCLUSIVE PROPERTY OF ARMORED WORKS, LLC. UNAUTHORIZED REPRODUCTION IS PROHIBITED.
DO NOT SCALE DRAWING



PART NUMBER DESCRIPTION 7002 CONTROL ARMS, JK UPPER FRONT

Section 3: Installation Instructions



Step 1: Remove Stock Components

Important Note: We strongly recommend that the vehicle be placed on an automotive lift and that all appropriate safety precautions be taken to secure the vehicle while it is off the ground. Always use the necessary axle stands (or equivalent) to support the axle when the suspension components are disconnected for safety, and to ensure the integrity of your suspension system during the installation process.

- A. Use an 18mm Socket & Wrench to remove the stock bolts. You will need a socket extension to access the head of the upper bolt inside the frame [A1].
- B. The exhaust on the passenger side of some models interferes with removal of the upper bolt. Cut the stock bolt



Section 3: Installation Instructions



Pre-Install 2: Set the length of the Control Arms.

Use the image below to identify and pre-set the lengths of your Control Arms. Hand tighten the Lock Nuts, for now.



		Front Control Arms		Rear Control Arms	
	Castor Angle	Lower	Upper	Lower	Upper
Factory Control Arms	Stock	22 5/8"	18 3/4"	19 3/4"	17 7/16"
MetalCloak 2.5 - 3.5" Lift	5 Degrees	23 1/16"	18 3/4"	20 7/16"	18 7/16"

Step 3: Install MetalCloak Front Upper Control Arms

Important Note: MetalCloak ships control arms at the approximate length for 3.5" lift kits. if you are doing a 2.5" kit, they control arms will need to be adjusted. whether 3.5" or 2.5" if you do not know the full dynamics of how to set up your control arms, please take your jeep to a professional for adjusting your caster and aligning your suspension.

- Using the stock bolts install the front upper control arm using the 18mm socket.
- Replace Passenger side bolt with the Flange Hex Head Bolt and Hex Flange Nut provided, using a 19mm socket install bolt from the outside of frame and the nut (19mm) inside the frame.
- Tighten the Lock Nut using a 1 1/2" wrench.

